

KG 6044 WV/G

iNDESIT

GB **Cooker with ventilated oven and electric hob**
Instructions for installation and use

Important safety warnings

- 1 **This appliance is intended for non-professional use within the home.**
- 2 **Before use your cooker, read the instructions in this owner's manual carefully since you will find all the instruction you require to ensure safe installation, use and maintenance. Always keep this owner's manual close to hand since you may need to refer to it in the future.**
- 3 When you have removed the packing, check that the appliance is not damaged. If you have any doubts, do not use the appliance, contact your nearest Service Centre. Never leave the packing components (plastic bags, foamed polystyrene, nails, etc.) within the reach of children since they are a source of potential danger.
- 4 The appliance must be installed only by a qualified technician in compliance with the instructions provided. The manufacturer declines all responsibility for improper installation which may harm persons and animals and damage property.
- 5 The electrical safety of this appliance can only be guaranteed if the cooker is correctly and efficiently earthed, in compliance with regulations on electrical safety. Always ensure that the earthing is efficient; if you have any doubts call in a qualified technician to check the system. The manufacturer declines all responsibility for damage resulting from a system which has not been earthed.
- 6 Before plugging the appliance into the mains, check that the specifications indicated on the date plate correspond to those of the electrical and gas mains system of your home.
- 7 Check that the electrical capacity of the system and sockets will support the maximum power of the cooker, as indicated on the data plate. If you have any doubts, call in a qualified technician.
- 8 An omnipolar switch with a contact opening of at least 3 mm or more, is required for the installation.
- 9 If the socket and cooker plug are not compatible, have the socket replaced with a suitable model by a qualified technician who should also check that the cross-section of the socket cable is suited to the power absorbed by the appliance. The use of adaptors, multiple sockets and/or extensions, is not recommended.
- 10 Do not leave the appliance plugged in if it is not in use. Switch off the main switch and gas supply when you are not using the cooker.
- 11 The openings and slots used for ventilation and dispersion of heat on the rear and below the control panel must never be closed or plugged.
- 12 The user must not replace the supply cable of this appliance. Always call an after-sales servicing centre authorised by the manufacturer in the case of cable damage or replacement.
- 13 This appliance must be used for the purpose for which it was expressly designed. Any other use (e.g. heating rooms) is considered to be improper and consequently dangerous. The manufacturer declines all responsibility for damage resulting from improper and irresponsible use.
- 14 A number of fundamental rules must be followed when using electrical appliances. The following are of particular importance:
 - do not touch the appliance when your hands or feet are wet
 - do not use the appliance barefooted
 - do not use extensions, but if these are necessary caution must be exercised.
 - never pull the power supply cable or the appliance to unplug the appliance plug from the mains.
 - never leave the appliance exposed to atmospheric agents (rain, sun etc.)
 - do not allow children or persons who are not familiar with the appliance to use it, without supervision.
- 15 Always unplug the cooker from the mains or switch off the main switch before cleaning or carrying out maintenance operations.
- 16 In the case of faults and/or faulty operation, switch off the appliance, close the gas cock and do not tamper with the cooker. For repairs call only an authorised after-sales servicing centre and request the use of original spare parts only. Failure to comply with the above may compromise the safety of the appliance.
- 17 If you are no longer using an appliance of this type, remember to make it unserviceable by unplugging the appliance from the mains and cutting the supply cable. Also make all potentially dangerous parts of the appliance, safe, above all for children who could play with the appliance.
- 18 One of the commonest types of accident involving cooking appliances is burns to babies and young children. These can occur by:
 - a) Touching hot parts
 - b) Being splashed with hot liquids
 - c) By pulling projecting pan handles and tipping hot liquids over themselves
- 19 Please remember that a small child's skin is far more sensitive and therefore more easily burnt than an adult. You are, therefore, strongly advised to keep babies and young children well clear of this appliance during use and whilst it is cooling down after use.
- 20 Unstable or out of shape pans should not be used on the hob in case they cause spillage of hot liquids.
- 21 Pans must only be placed in the centre of electric rings and of grids on gas burners. Placing pans off centre or to one side may cause spillage.
- 22 Special care should be taken when using chip pans etc. in order to avoid splashing or spillage of hot oil. They should not be used unattended since overheated oil may boil over and ignite on the hot heating element or gas flame.
- 23 Parts of this appliance, particularly hob hot plates, retain heat for considerable periods after switching off. Care should, therefore, be taken when touching these areas before they have completely cooled down.
- 24 Petrol and other inflammable solvents should not be used in the vicinity of the appliance whilst it is in use.
- 25 **When you are using the grill or the oven, some parts of the door can become very hot. Keep children away from these.**
- 26 To avoid accidental spillage do not use cookware with uneven or deformed bottoms on the electric plates.
- 27 Make sure the knobs are in the "•"/"o" position when the appliance is not in use.
- 28 Before opening the cover, make sure to remove any liquids that might be on it.

Installation instructions

The model of appliance are indicated on the rating plate on the plinth and is visible when drawer is fully pulled out of runner. The serial number of the cooker is printed on the rating plate.

- 1) The cooker can be positioned against the side walls of other kitchen furniture. However, if the side **walls of the adjacent cabinets don't withstand up to 60°C** temperature rise, a minimum gap of 10 mm (3/8") must be left between the sides and the back of the cooker and the adjacent cabinets for the circulation of air. The wall behind the cooker must be of flameproof material and withstand up to 80°C temperature rise. **The cooker is covered by degree of protection X. The height of furniture installed next to the cook must not exceed that of the work top.**

Caution: INDESIT are unable to accept any responsibility for failure to comply with the above instructions for cooker installation.

Cable connection to the cooker

To get access to the terminal board remove cover "D" using a screwdriver.

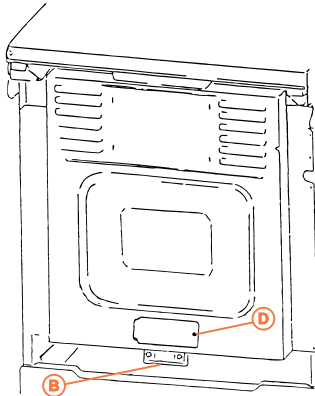

The electrical connection must be done in accordance with following diagram:

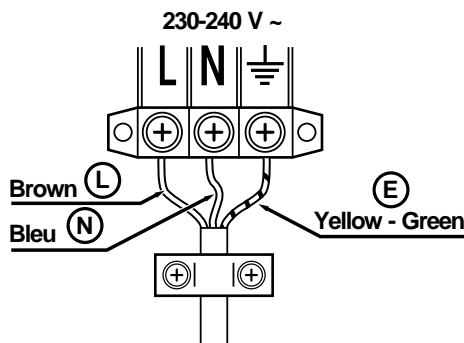

Cable H05RRF - 3 x 2,5 mm²

Connection to an electricity supply

These appliances must be installed by a competent electrician with all electrical connections in accordance with the Regulations for the Electrical Equipment of Buildings, published by the Institution of Electrical Engineers. A Double-Pole switch must be provided no further than 2 metres from the appliance to control the electrical supply. This product must be earthed and fused in accordance with current rating of the appliance. Before fitting please ensure that voltage indicated on the rating plate corresponds to the mains voltage in your home. The supply to which the cooker is connected should be equal to or higher than the power absorbed by the cooker. The rating plate provides information on Model Number, voltage rating and frequency of this appliance.

WARNING: This appliance must be earthed

Cable connection to the cooker

The earth screw is located at the back of the cooker near the terminal board. See above diagram.

Important: INDESIT are not liable for any loss or damage caused by the non observance of the above instructions.

IMPORTANT NOTE - It is important when inserting the cable wires (E, L, N) into the relevant slots on the mains terminal block, to ensure the bared wire is cramped between the brass plates of the block, as shown in the diagrams.

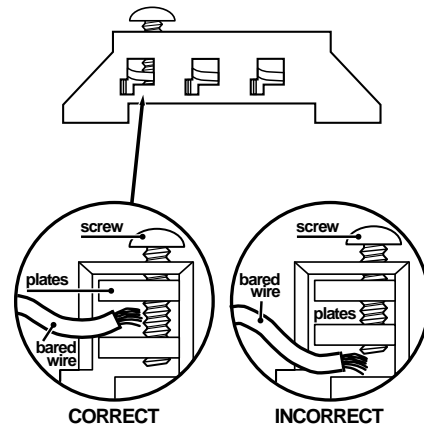

Technical characteristics

Dimensions of the oven:

- width	cm 44
- depth	cm 41
- height	cm 29,5

Volume of the oven:

53 Liters

Dimensions of food-warmer drawer:

- width	cm 51
- depth	cm 48
- height	cm 8



This appliance conforms with the following European Economic Community directives:

- 73/23/EEC of 19/02/73 (Low Voltage) and subsequent;
- 89/336/EEC of 03/05/89 (Electromagnetic Compatibility) and subsequent;
- 93/68/EEC of 22/07/93 and subsequent.

Mains frequency and voltage of the electrical section

Model	Electric section	
	Voltage	Power (W)
KG 6044 WV/G	230/240 V ~ 50 Hz	8900 - 9000

Control panel

All the controls of the cooker are grouped on the hob face panel

- A Control knob for oven
- B Control knob for variable grill
- C Control knob for hob hot plates
- D Timer or programmer knobs
- E Pilot lamps
- F The red oven-operating pilot lamp

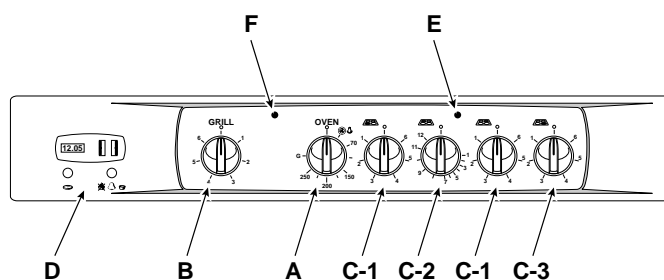

C-1 145 FAST PLATE 1.5 kW
 C-2 180 FAST PLATE 2.0 kW
 C-3 220 STANDARD PLATE 2.0 kW

Slight variation on controls may exist from model to model.

Instructions for use

Before use

Please ensure that any protective film and all packing has been removed from the cooker before switching on. Allow all elements to run for a short period to burn off any residue from their surfaces.

Electric Cut Out

This cooker has a safety cut out device which switches OFF the electric plates when you close the lid. This device is obviously provided for safety in case the user closes the lid with the plates on. Always allow electric plates to cool before closing the lid. Failure to follow these instruction may cause the glass lid to shatter. When you open the lid, the plates will switch ON again. Keep the lid open when using the oven.

Electric hob

The cooker is equipped with standard and fast hot plates. We recommend the use of utensils with thick, flat bases specially designed for electric cooking. The diameter of the base must be the same or slightly greater than that of the plate.

Please Note: discolouring of the sealing ring around the base of the hot plate will be experienced. Never operate the plates without anything on them. The indicator light (E) comes on when the plate is operating.

WARNING

Do not attempt to operate the hob when the lid is down. Do not close the lid when the hob is in operation. After use allow hot plates to cool before closing lid.

Fast and standard plates

Every electric hot-plate is controlled by a knob on the control panel and has six positions plus the "off" position. Position "1" has minimum power.

Position "6" maximum power.

When the cooker is new it is advisable to use the plates on minimum position for 30 min. without any pans.

Setting	Normal or Fast Plate
0	Off
1	Cooking vegetables, fish
2	Cooking potatoes (using steam) soups, chickpeas, beans.
3	Continuing the cooking of large quantities of food, minestrone
4	For roasting (average)
5	For roasting (above average)
6	For browning and reaching a boil in a short time.

The cook-top pilot lamp (E)

This turns on whenever any electric heating element in the cook-top is on.

The red oven-operating pilot lamp (F)

The light, situated to the left of the oven thermostat knob, signals when the oven is heating. It switches off when the temperature inside the oven reached the temperature selected by the knob. At this point the alternate turning on and turning off of this light indicates that the thermostat is operating correctly to keep the oven temperature constant.

Forced air oven

Development of "Forced Air" Oven has meant substantial reductions in running cost in comparison with conventional cooking appliances. The term "Forced Air" is as the name implies, a method of cooking with the air forced firstly over the heating elements and then horizontally through the oven cavity. The benefits of this are numerous, it ensures further utilisation of the heat generated by the heating elements to provide even temperature throughout the oven cavity, also to reduce oven pre-heating times and enable cooking to be done at lower temperatures. With even heat distribution the advantages are to cook at the same time at different levels the same or different types of food, such as roast and fish. This fact can only be made possible in a "Forced Air" Oven, because volatile substances containing odours and flavours with a molecular structure soluble in water, flavour contamination can pass into a body being heated only if there is condensation. With "Forced Air" this cannot happen, the immediate heating of the external surfaces of the food makes the surfaces dehydrate creating a protective barrier preventing absorption. Coupled with the fact that the expelled by the fan is pushed through a heating element a sterilisation effect of odours occurs. Although a reduction in both temperature and duration of cooking is necessary, these adjustments will be done according to your personal taste. As a guide we would recommend a reduction of ten minutes in every hour of cooking with a reduction of 20°C in every 100°C of temperature in comparison with a conventional oven.

Operation

A knob located on the control panel controls the following oven operations:

- Defrosting with cold air ☼
- Cooking 70°C-250°C
- Grill G

Commissioning

The cooker is equipped, with a mechanical automatic programmer (Fig. A). Before operating the oven or the grill, ensure that the symbol ☼ coincides with the pointer on dial 4.

- When the button is pushed, in the oven the light comes on.
- When the knob is set to the symbol ☼ the fan operates for defrosting frozen products without any heat.
- The control knob can be set on temperatures ranging from 70°C to 250°C which will enable you to select the temperatures best suited to your cooking.
- To operate the infra-red grill, set the knob on the symbol G (in which case the oven circo-fan will not operate).

The oven and grill warning-light remains on during operation.

Note: Whilst operating the grill ensure the oven door is ajar in the vertical position and the heat deflector is correctly positioned (see Fig. A).

The guard plate gets hot when the grill is used. Remove it with care, using an oven glove or similar, and put it away carefully in a safe place. The guard plate must be removed before attempting to fully close the oven door.

Caution: To operate the Grill Pan use the proper handle as shown in figure B.

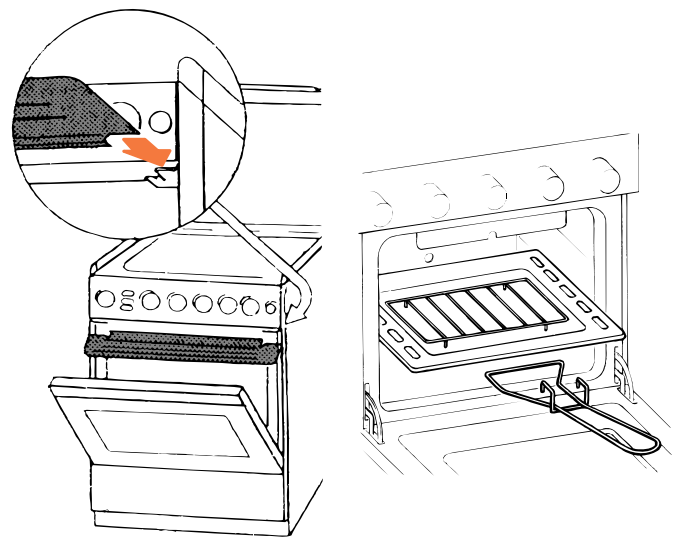

Operation of the Variable Grill

The variable grill is controlled by knob B. Before operation, adjust the oven control knob to position G. Position "1" corresponds to minimum power, position "6" corresponds to maximum power. On "0" position the grill doesn't operate.

When you are using the grill or the oven, some parts of the door can become very hot. Keep children away from these.

Useful hints

- Only use pans which are heat resistant up to 300°C.
- The oven double glass reduces the temperature of the oven door, avoid however touching the glass when the oven is operating.
- While grilling, position the tray on the first shelf.

Defrosting of foods in the oven

Defrosting occurs in the same way as at room temperature; however at a faster rate. Electric power consumption for the defrosting of foods is very low (ab. 0.38 kWh/hr).

Cooking

Different types of foods placed on the various cooking shelves of the oven can be cooked simultaneously without any mixing up of smells. A considerable saving of electric power is also achieved at the same time. When several oven shelves are used for simultaneous cooking of various foods, always leave some space from one pan to the other for better air circulation.

Make sure that air circulation slots on the bottom wall of the oven are not obstructed. It is advisable to always use aluminium pans, ensuring that the foods contained therein do not overflow, as this could cause burning due to the flow of hot air. The intermediate oven shelves should be used when single cooking is done.

Cooking tables

The following chart provides Gas Oven Marks approximate conversions from degrees Fahrenheit to degrees Celsius (formel known as Centigrade).

This chart can be used for conversions of recipes which give oven temperatures of °F or gas mark. However do ensure a reduction is made to temperature and cooking times with Forced Air cooking: -20° in every 100°C, ten minutes in every hour.

OVEN TEMPERATURE GUIDE				
Gas Mark	Descript.	Electricity		Forced Air Oven Approximate Settings °C
		°F	°C	
1/4 1/2	COOL	230 250	110 121	90 100
1/2 1	VERY SLOW	250 275	121 135	100 110
1 2	SLOW	275 300	135 149	110 120
2 3	VERY MODERATE	300 350	149 177	120 145
4	MODERATE	375	190	150
5	MODERATE HOT	400	204	160
6 7	HOT	425 450	218 233	175 190
8 9	VERY HOT	475 500	246 260	205 210

Caution

H. M. Government Ministry of Agriculture Fisheries and Food announcement necessitates the following warning. The insertion of foodstuffs covered in close wrap plastic (cling film) into utensils for cooking or within the oven for baking/roasting is not recommended as it is possible that certain elements of the plastic film can be absorbed by foodstuffs when subjected to heat.

The cooking programmer

The cooking programmer

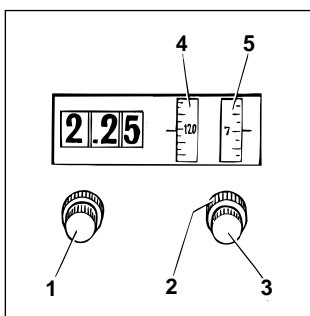

The figure shows the programmer controls. All the necessary settings can be made knobs 1, 2 and 3.

Knob 1

Turn knob clockwise to set correct digital clock time (for example: when installing the appliance, after current failures, to set ahead or back, etc.)

Knob 2

- Turn knob clockwise to set the following:
- cooking time (maximum 210 minutes);
 - sound signal turn-off (setting \otimes);
 - manual oven operation (setting ⏏);

The above signals appear on dial 4.

Knob 3

Press in and turn the knob clockwise or counter clockwise to set the starting cooking time on dial 5. When setting the clock, make sure the time shown on the clock is synchronized with the time indicated on dial 5.

Manual oven operation

The oven can be used normally, that is without any programming. In this case turn knob 2 of the programmer clockwise till symbol ⏏ coincides with the pointer on dial 4.

Semiautomatic oven operation

Normal cooking start, programmed end of cooking: place the food in the oven; turn knob 2 of the programmer clockwise and on dial 4 set the minutes required to complete the cooking; turn the oven knob to the the desired temperature. Make sure the time shown by the clock is synchronized with the time indicated on dial 5.

Automatic oven operation

Place the food in the oven: turn knob 2 clockwise to set the required cooking time on dial 4; press in and turn knob 3 clockwise to set the cooking start time on dial 5; turn the oven knob to the desired temperature. When cooking is completed the "0" on dial 4 will be opposite the pointer; this setting indicates the oven

is no longer on. A sound signal tells the user cooking is ended. To stop the sound signal, turn knob 2 clockwise till symbol  is opposite the pointer on dial 4.

Example of programmer setting with oven operating automatically:

End of cooking time: 7 p.m. (or 19.00 hours continentals time).

Cooking time: 2 hours.

Place the food in the oven: turn knob 2 clockwise to set the cooking time on dial 4 (that is, 2 hours); press in and turn knob 3 clockwise to set the cooking start time on dial 5 at 5 p.m. (or 17.00 hours); turn the oven control knob to the desired temperature.

After completing these operations, the programmer will make the oven operate automatically from 5 p.m. to 7 p.m.

Minute timer

The programmer can serve as a timer only if no automatic programs have been set up and the **oven is off**. To use the timer, turn knob 2 clockwise to set the required time on dial 4. The maximum programmable time is 210 minutes. To stop the sound signal, turn knob 2 clockwise till symbol  appears opposite the pointer on dial 4.

Programmed cooking

Programmed cooking is no different from normal cooking. The programmer system can control the cooking time while the user is out or doing other tasks; consequently, foods requiring no particular attention while cooking are to be preferred for automatic cooking operations.

The programming of a time past 12 p.m., if you calculate by continental time, must always be referred to by using the first 12 hours of the day, for example: the time 20.00 hours must be understood as 8 and so on; therefore, it is possible to program cooking 12 hours in advance.

Important

To use the oven without any programming it is necessary:

1. When setting the clock, make sure **the time shown on the clock is synchronized with the time indicate on dial "5"**.
2. Turn knob "2" of the programmer clock-wise till symbol  coincides with the pointer on dial "4".

Routine maintenance and oven cleaning

Before each operation, disconnect the cooker from the electricity. To assure the long life of the cooker, it must be thoroughly cleaned frequently, keeping in mind that:

- the enamelled parts and the self-cleaning panels are washed with warm water without using any abrasive powders or corrosive substances which could ruin them;
- the inside of the oven should be cleaned fairly often while it is still warm using warm water and detergent, followed by careful rinsing and drying;
- the electric plates are cleaned with a damp cloth and they should be lubricated with a little oil while they still warm;
- the stainless steel parts should be rinsed with water and dried with a soft, clean cloth or chamois. In case of difficult spots, use normal, non abrasive detergents available on the market or else a little warm vinegar;
- in models with glass covers, the covers are cleaned with hot water, and use of rough cloths or abrasives is to be avoided.

N.B: avoid closing the cover while the electric plates are still warm.

Replacing the oven light bulb

- Either pull out the plug (if it is accessible) or disconnect the oven from the mains by turning off the multipole switch used for connecting the oven to the electricity source;
- Remove the glass cover of the lamp holder;
- Unscrew the bulb and replace it with a high temperature resistant bulb (300°C) with the following characteristics:
 - Voltage 230V
 - Wattage 25W
 - Type E14
- Replace the glass cover and reconnect the power supply to the oven.

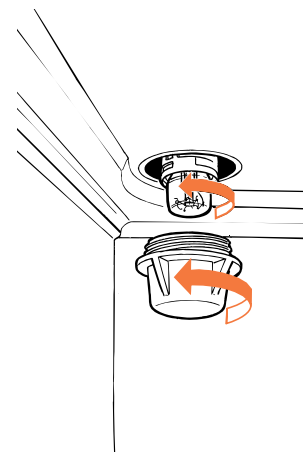

3° Glass

You can buy a special kit to reduce door temperature when the oven is on and save energy. If there are little children in the house, this kit is a must. The kit code number is **039888** and it may be purchased for installation from an authorised dealer or a Technical Assistance Service centre indicated in the list included with the appliance documents.

Internal oven door glass

This can be dismantled to facilitate cleaning the oven:

- unscrew the two screws on the sides;
- remove the glass and clean with a damp cloth;
- replace the glass ensuring that the two disks fit under the screws.

Important: the oven must never be used without the internal glass.



Merloni Elettrodomestici spa
viale Aristide Merloni, 47 - 60044 Fabriano
tel. 0732/6611 - telex 560196 - fax 0732/662954
www.Merloni.com

Cucina con forno ventilato e piano elettrico
02/99 - 195013907.02 Xerox Business Services - Docutech